

1. Reflow soldering only, not suitable for wave or hand soldering, except type 933 can be wave soldered.
2. Use of flux or cream solder should be limited to one with a halogen content of 0.1% or less.
3. Parts are rated for one soldering only. Do not remove from board and attempt to resolder.
4. Cleaning conditions :
 - (1) Isopropyl alcohol is the recommended cleaning agent.
 - (2) Dichloroethane, trichloroethylene, toluene, xylene, MEK and water may not be used.
 - (3) After cleaning, the board must be dried.
5. Storage at cool temperature and low humidity is recommended.
6. Flame retardancy: These capacitors are not encapsulated and as such, do not meet any flame retardancy standard.
5. Types 932, 932D, 932X, 933, 933X and 935X should not be connected directly across a primary AC line.

CAPACITANCE VS. TEMPERATURE

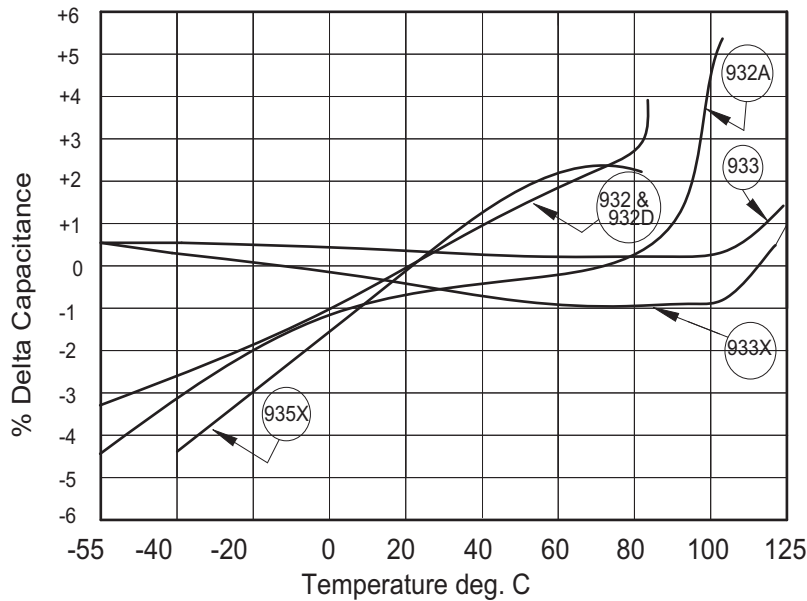

RECOMMENDED PAD DIMENSIONS

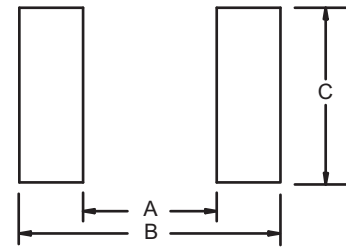

EIA SIZE	A (mm)	B (mm)	C (mm)
0603	0.8	2.0	0.7
0805	1.0	2.7	1.1
1206	2.2	3.8	1.4
1210	2.2	3.8	2.3
1913	2.6	6.6	3.0
2416	3.8	7.8	3.8
2420	3.8	7.8	4.6
2820	4.5	9.0	4.6
2825	5.1	9.7	5.0
3022	4.5	9.0	5.7
3925	7.2	11.9	5.7
3931	7.2	11.9	7.2
6032	12.6	17.3	7.2
6039	12.6	17.3	9.0

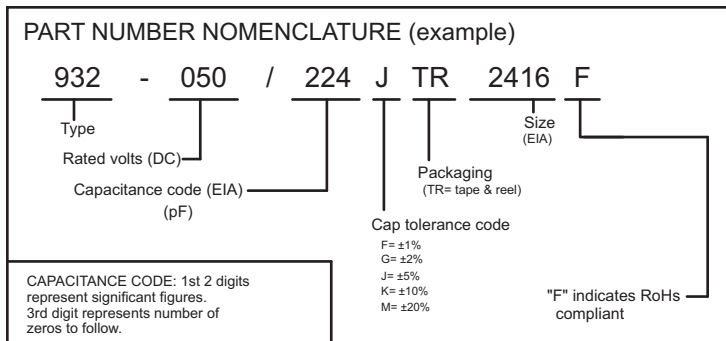

SMD FILM SOLDER PROFILE

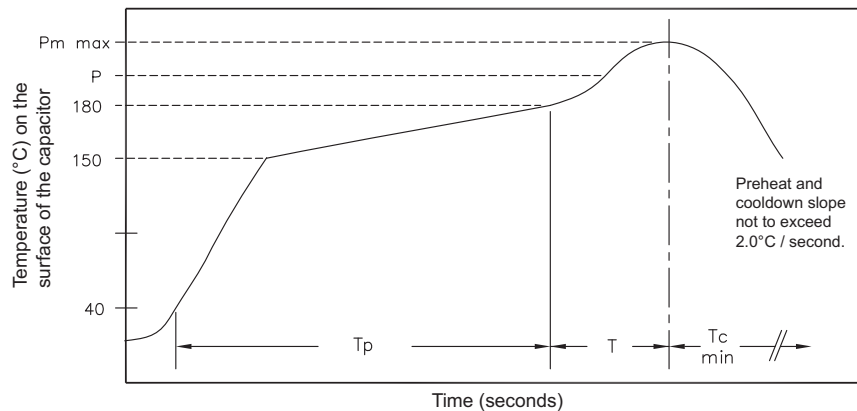

Type	Size	Pm Peak Temp (°C)	Max. Time @ Pm (Seconds)	T	Tp	Tc	P (°C)	Max. Time Over P (Seconds)
		Max.	Max.				Max.	Max.
931AF	2220-2840	245	10	20-50	60-150	120	220	30
931AF	4030-6054	250	10	20-50	60-150	120	220	30
931AF	except 430 & 630V	240	10	20-50	60-150	120	220	30
932	All	240	5	20-50	60-150	120	220	60
932AD	2824-2840	255	10	20-50	60-150	120	220	60
932AF	1206-1812	250	10	20-50	60-150	120	220	60
932AF	2220-6054	255	10	20-50	60-150	120	220	60
932D	All	240	5	20-50	60-150	120	220	60
932X	All	240	5	20-50	60-150	120	220	30
933	All	260	5	20-50	60-150	120	230	30
933AF	All	260	10	20-50	60-150	120	230	30
933x	All	260	5	20-50	60-150	120	230	30
935X	All	240	5	20-50	60-150	120	220	30

CLEANING CONDITIONS;

Alcohol (Isopropyl alcohol - IPA): Ultrasonic washing or immersion washing for 5 minutes at less than 50°C.

CAUTIONS:

1.0 Do not use water for cleaning. Film chip style capacitors do not have encapsulation. Invasion of water will degrade (lower) the insulation resistance. The use of a high pressure water spray for rinsing may delaminate the outer layer of the capacitor element and/or surface peeling may occur.

2.0 Do not use Dichlorethane, trichlorethylene, toluene, xylene, Alcohol (Ethanol) or MEK.

3.0 After cleaning, the board must be dried.

4.0 Since chip capacitors do not have encapsulation, components of flux or detergent left over in the capacitor element after washing may be activated and invade the inside of the capacitor causing degradation of the electrical characteristics.

5.0 Use of flux and/or cream solder should be limited to one with a halogen content of 0.1% or less.

6.0 When using ultrasonic cleaners, peeling of the protective surface of the capacitor, separation of the electrodes and/or degradation of the electrical characteristics may occur.

TAPING SPECIFICATIONS:

Embossed Plastic Carrier Tape (Complies with EIA 481)

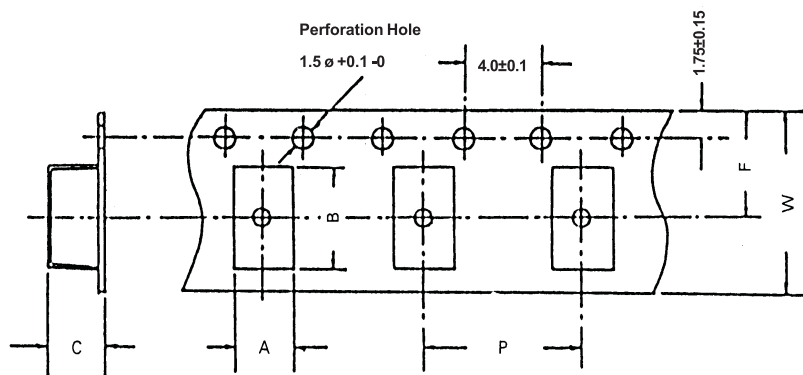

REEL

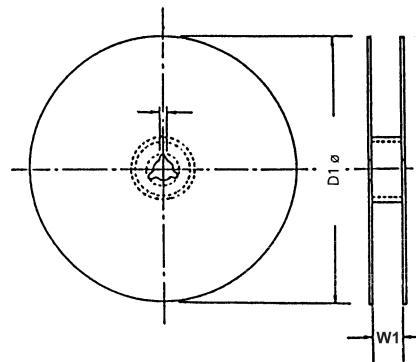

TAPE AND REEL CHARACTERISTICS AND PACKAGING QUANTITIES (millimeters)

Size Code	Tape Dimensions				Reel dimensions			Tape Qty/Reel	D1 nom
	T max.	W	P	C	A	W1	W2 max.		
1206	1.1	8	4	1.20	180	8.4	14.4	3900	180
	1.3			1.40				3400	
1210	1.8	8	4	1.90	180	8.4	14.4	2500	180
	2.3			2.33				2000	
1812	1.5	12	8	1.60	180	12.4	18.4	1500	330
	2.0			2.06				1200	
	2.5			2.60				900	
	3.0			3.10				700	
2220	1.5	12	8	1.60	180	12.4	18.4	5800	330
	2.0			2.06				4500	
	2.5			2.60				3600	
	3.0			3.10				3000	
	2.0			2.10				4400	
	2.1			2.18				4300	
2824	2.8	16	12	3.10	330	16.4	22.4	3000	330
	3.0			3.45				2800	
	4.0			4.10				2300	
	4.5			4.60				1900	
4030	3.6	24	12	3.73	330	16.4	22.4	1600	330
	5.0			5.23				1100	
	5.1			5.50				1000	
5040	5.6	16	12	5.90	330	16.4	22.4	900	330
	3.8			3.93				1400	
	4.8			4.90				1100	
6054	6.0	24	16	6.19	330	24.4	30.4	900	330
	3.8			4.00				1100	
	4.6			4.70				900	
	5.5			5.70				700	
6054	6.6	24	16	7.00	330	24.4	30.4	600	330
	4.4			4.50				600	
	4.8			5.50				500	
	6.2			6.30				400	
6054	7.0	24	24	7.60	330	24.4	30.4	300	330

TAPING SPECIFICATIONS:

Embossed Plastic Carrier Tape

Perforation Hole

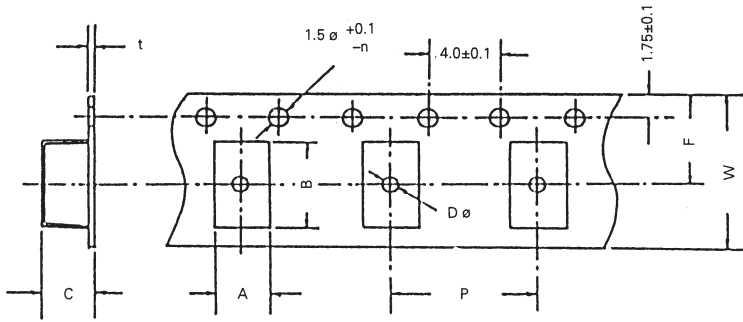

REEL

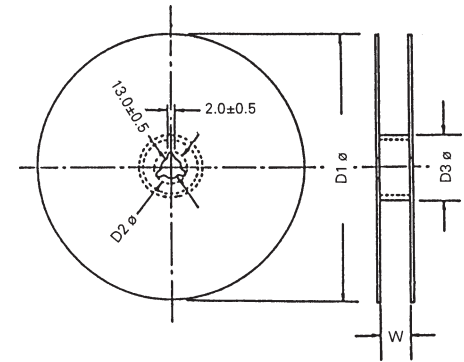

TAPE DIMENSIONS (MM)

Size	Thickness	A ± 0.1	B ± 0.1	C ± 0.2	t ± 0.2	W ± 0.3	F ± 0.05	P ± 0.1	D -0+ 0.2
1913	1.4	3.8	5.1	2.0					
	2.0			2.6					
	2.4 & 2.8			3.4					
2416	1.8	4.6	6.3	2.7	.30	12	5.5	8	1.5
	2.0 & 2.4			3.5					
	2.8 & 3.2			4.6					
2420	3.2 & 3.8	5.5	7.5	4.7					
2820 (ALL)	5.685								
2825 (ALL)		6.91	8.43	5.795		16	7.5	12	
3022 (ALL)									
3925 (ALL)		8.94	10.54	5.795					
3931 (ALL)									
6032	3.7 & 4.4	10.8	16.0	5.81	.35	24	11.5	16	
6039	4.2 & 5.1								

REEL DIMENSIONS (MM) & QUANTITY PER REEL (PCS)

Size	Thickness	QTY/REEL	D1 ± 2.0	D2 ± 0.8	D3 ± 1.0	W ± 1
1913	1.4 & 2.0	3000	330	21	80	13.4
	2.4 & 2.8	2000				
2416	1.8 & 2.0	3000				
	2.4, 2.8 & 3.2	2000				
2420	(ALL)	1500				
2820	(ALL)	1000				
2825	(ALL)	750				
3022	(ALL)					
3925	(ALL)					
3931	(ALL)					
6032	(ALL)					
6039	(ALL)					

HANDLING CAUTIONS AND RECOMMENDATIONS:

1. Recommended Land Pattern (mm)

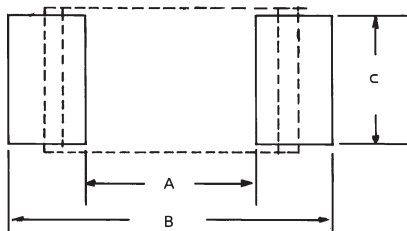

Size	A	B	C
1913	2.6	6.6	3.0
2416	3.8	7.8	3.8
2420			4.6
2820	4.5	9.0	5.0
2825	5.1	9.7	
3022	4.5	9.0	5.7
3925	7.2	11.9	
3931			
6032	12.6	17.3	9.0
6039			

GENERAL INFORMATION

CMC chips can be supplied with established reliability screening per MIL-C 55681, or high reliability screening upon request.

Storage: Parts should be stored @ a max temperature of 40°C in an environment where humidity is less than 70% and should not be exposed to harmful gas such as chlorine or sulfurous gas which can affect solderability. Parts should be used within 6 months after being opened or unpacked from original reel or bulk packaging. After being unpacked for more than 94 days, solderability should be checked before using.

IR REFLOW SOLDER PROFILE FOR CMC FAMILY

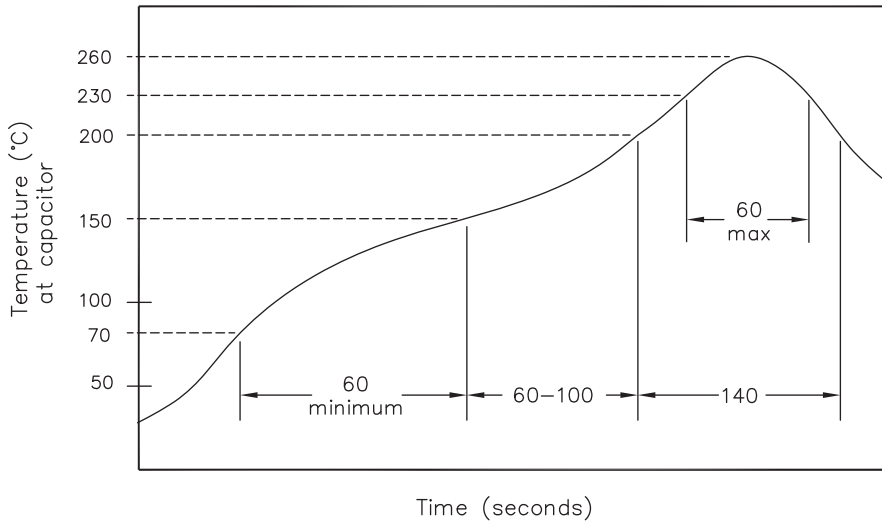

For use on types: CMC, CMC(HC), CMCF, CMCS, CMT, and CMX.

Heating: Do not heat faster than 3°/sec for sizes up to and including 1206 and 2°/sec for sizes 1210 and over.

Maximum temp: 260°C, 10 seconds maximum.

Cooling: No forced cooling. Maximum cool rate of 2°C /second.

RECOMMENDED PAD DIMENSIONS

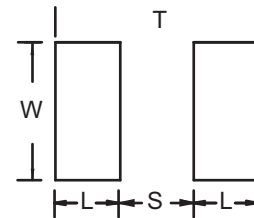

PART NUMBER NOMENCLATURE (example)						
CMC	-	016	/	104	K X 0603 T 13 F	
Type	Rated volts (DC)	Capacitance code (pF)	Cap tol. code	TC N= NPO X= X7R Z= Z5U Y= Y5V X5= X5R	Size code (EIA)	Reel size Packaging (T= tape & reel) (W= Waffle pack)
CAPACITANCE CODE: 1st 2 digits represent significant figures. 3rd digit represents number of zeros to follow.		F= ±1% G= ±2% J= ±5% K= ±10% M= ±20%	"F" indicates RoHs compliant blank indicates non-RoHs compliant			

SIZE	L	W	S	T
0201	0.012	0.018	0.010	0.040
0402	0.021	0.022	0.017	0.059
0504	0.035	0.050	0.020	0.080
0803	0.035	0.030	0.030	0.400
0805	0.040	0.050	0.040	0.120
1005	0.040	0.050	0.060	0.140
0907	0.040	0.070	0.050	0.130
1206	0.040	0.085	0.080	0.160
1210	0.040	0.100	0.080	0.160
1505	0.040	0.050	0.110	0.190
1805	0.040	0.050	0.130	0.210
1808	0.050	0.080	0.130	0.230
1812	0.050	0.120	0.130	0.230
1825	0.050	0.250	0.130	0.230
2225	0.050	0.250	0.170	0.270
3640	0.060	0.400	0.300	0.420

TAPE & REEL QUANTITIES

SIZES	STANDARD TERMINATION		
	8mm		12mm
Embossed carrier Punched carrier	0201	0603-1210	1812-1825
Punched only	-	0403-0603	-
Pieces/7" Reel	15,000	2,000 (4,000 low T)	1,000
Pieces/13" Reel	-	10,000	4,000

- Cleaning conditions :
 - (1) FREON TE, TES, TP35, 2 minutes maximum @ 40°C
 - (2) CFC substitute solvents, 2 minutes maximum @ 60°C
 - (3) Post cleaning water wash (3-5 minutes) is recommended.
 - (4) Tecate Industries recommends the use of CFC substitutes whenever possible.
 - Recommended storage @ 40°C and 70% RH max.
 - Polarity, All polar capacitors have polarity marking. Cathode is marked by black band on top of the can. MXNP series is non-polarized and can be used where circuit polarity is reversible or unknown.
 - Reflow Soldering only, not suitable for Wave or Hand Soldering.
- Maximum temperature and time limits shown below:

IR REFLOW SOLDER PROFILE FOR MXX FAMILY

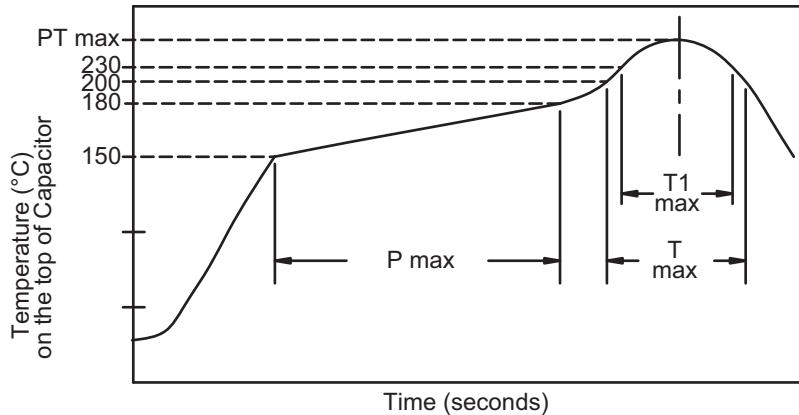

PT: Peak temperature not to be exceeded.
 T: Maximum time above 200°C (seconds).
 T1: Maximum time above 230°C (seconds).
 P: Maximum pre-heat time between 150°C and 180°C.
 Reflow exposures: 2 maximum with complete cool down between exposures.

TYPE	VOLTAGE	DIAMETER	PT PEAK TEMP	T TIME	T1 TIME	P TIME
MXLL, MXLX, MXM, MXMH, MXMS, MXNP, MXNW, MXW, MXWL, MXZ, MXZM, MXZX, MXZZ, MXWH	4-63	3-6.3	250	70	40	120 AT 150-180C
		8	245	60	30	120 AT 150-180C
		10-12.5	240	50	20	120 AT 150-180C
		16	235	50	15	120 AT 150-180C
	80-100	4-6.3	250	60	40	120 AT 150-180C
		8	240	60	30	120 AT 150-180C
		10	240	50	20	120 AT 150-180C
		12.5	235	50	20	120 AT 150-180C
	160-400	16	235	45	10	120 AT 150-180C
		8-10	240	50	20	120 AT 150-180C
		12.5	235	45	10	120 AT 150-180C
		16	230	30	0	120 AT 150C
* R SUFFIX	4-63	8-10	250	70	40	120 AT 150-180C
MXWRU, MXWZ, MXLX	6.3-50	4-8	260	80	40	120 AT 150-180C
		10	250	70	40	120 AT 150-180C
		12.5	240	50	20	120 AT 150-180C
		16	235	50	15	120 AT 150-180C
	63	8	245	60	30	120 AT 150-180C
		10-12.5	240	50	20	120 AT 150-180C
		16	235	50	15	120 AT 150-180C
		8	240	60	30	120 AT 150-180C
	100	10	240	50	20	120 AT 150-180C
		12.5	235	50	20	120 AT 150-180C
		16	235	45	10	120 AT 150-180C
		8	240	60	30	120 AT 150-180C
MXLP, MXWE, MXZW	ALL	ALL	245	60	30	120 AT 150-180C
MXWM, MXWP	ALL	ALL	240	50	20	120 AT 150-180C
MXMM	ALL	ALL	230	30	0	120 AT 150C
MXLH	ALL	ALL	230	20	5	120 AT 150C
MXML	ALL	ALL	230	30	5	120 AT 150C

For any ±10% (K) part, use MXML profile.

*NOTE: Type suffix "R". High temperature solderable unit. Type is available on any unit in 8mm or 10mm diameter and below 63VDC.

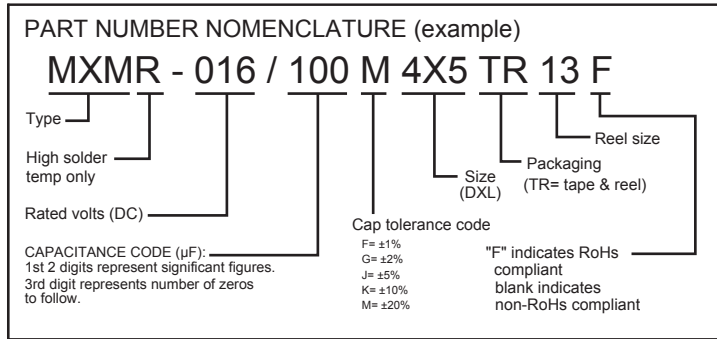

RECOMMENDED PAD DIMENSIONS

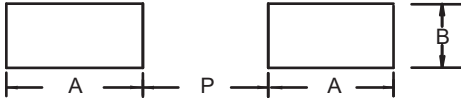

SIZE	A	P	B
3 x 5.5	2.2	1.6	0.8
4 X 5.5	2.6	1.6	1.0
5 X 5.5	3.0	1.6	1.4
6.3 X 5.5	3.5	1.6	2.1
6.3 X 6.3			
6.3 X 8			
8 X 10.5	4.15	1.9	2.8
10 X 10.5	4.4	1.9	4.3
12.5 X 14	5.65	2.1	4.3
16 x 17	6.5	5.0	6.6

TAPING SPECIFICATIONS:

1. Leader and ending tape: Min. 10 empty pockets and 20 cm of cover tape.
2. Connection: Within 3 connections per reel.

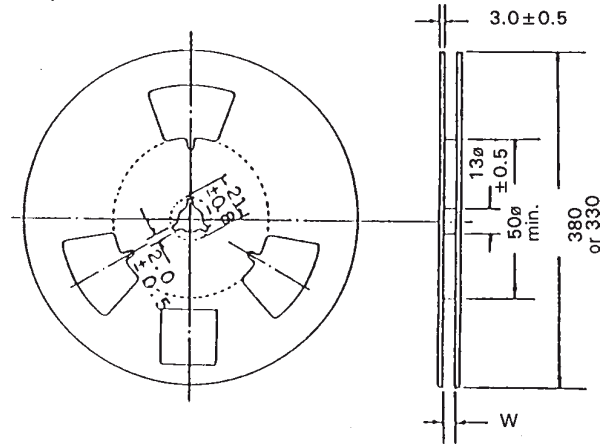
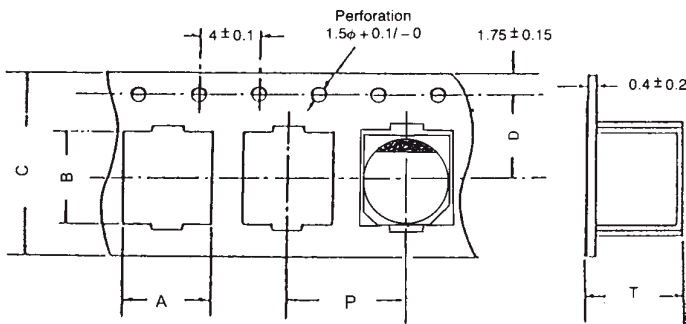

Case Size	A* ± 0.2	B* ± 0.5	C ± 0.3	D ± 0.1	P ± 0.1	T ± 0.2
4 x 5.5	4.7	4.7	12.0	5.5	8.0	5.8
5 x 5.5	5.7	5.7	12.0	5.5	12.0	5.8
6.3 x 5.5	7.0	7.0	16.0	7.5	12.0	5.8

*Dimensions at bottom of embossed pocket.

330mm (13") REEL

Case Size	W ± 1	Q'ty per reel
4 x 5.5	14.0	1,500 pcs
5 x 5.5	14.0	1,000 pcs
6.3 x 5.5	18.0	1,000 pcs

380mm (15") REEL

Case Size	W ± 1	Q'ty per reel
4 x 5.5	14.0	2,000 pcs
5 x 5.5	14.0	1,000 pcs
6.3 x 5.5	18.0	1,000 pcs

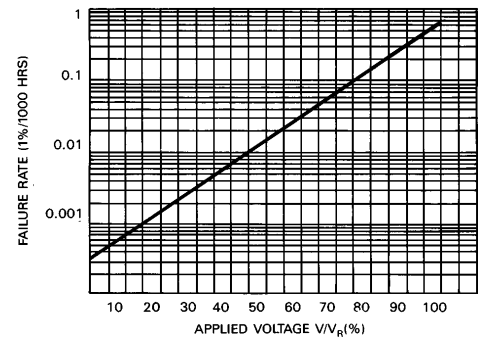
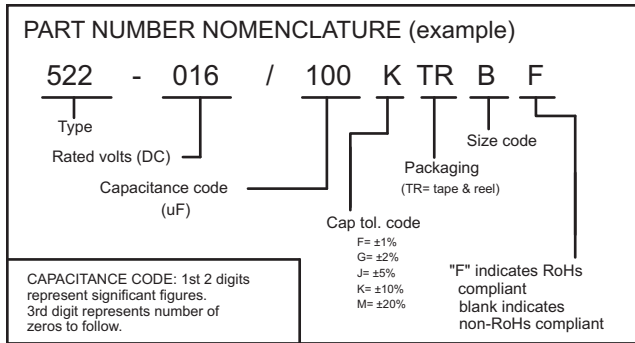

OPERATING VOLTAGE/VOLTAGE DERATING

- If a capacitor with a higher voltage rating than the maximum line voltage is used, then the operating reliability will be improved. This is known as voltage derating. The graph at right shows the relationship between voltage derating (the ratio between applied and rated voltage) and failure rate. The graph gives the correction factor F(V) for any operating voltage.
- Where less than 0.1Ω per volt series resistance is employed, a 70% derating factor is recommended. Consult factory for further information under these conditions.

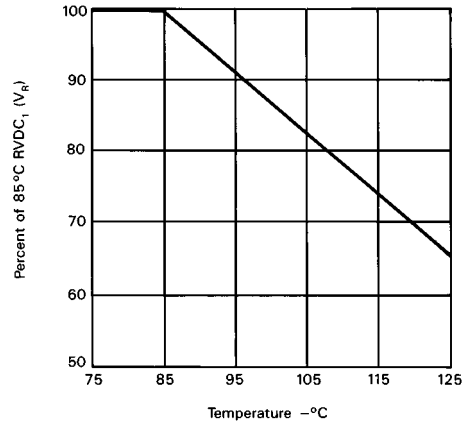

RATED DC VOLTAGE

- This is the rated DC voltage for continuous operation up to +85°C.
- Category voltage.
- This is the maximum voltage that may be applied continuously to a capacitor. It is equal to the rated voltage up to +85°C, beyond which it is subject to linear derating to 2/3VR at 125°C.

SURGE VOLTAGE

- This is the highest voltage that may be applied to a capacitor for short periods of time. The surge voltage may be applied up to 10 times in an hour for periods of up to 30 seconds at a time. The surge voltage must not be used as a parameter in the design of circuits in which, in the normal course of operation, the capacitor is periodically charged and discharged.

Rated Voltage (VDC)	85°C		125°C	
	Surge Voltage (VDC)	Category Voltage (VDC)	Surge Voltage (VDC)	Category Voltage (VDC)
2	2.7	1.3	1.7	1.3
4	5.2	2.7	3.2	2.7
6.3	8	4	5	4
10	13	7	8	7
16	21	10	13	10
20	26	13	17	13
25	32	17	20	17
35	46	23	30	23
40	52	25	33	25
50	65	33	43	33

SHELF LIFE

- When Aluminum capacitors have been stored for long periods of time without having voltage applied, leakage current will be very high when voltage is applied. This can cause internal heating and pressure build-up inside the case (sometimes enough to rupture the vent). The amount of time that capacitors can be stored safely depends on the voltage rating of the capacitor and the storage environment. Humidity levels should be under 50% and temperature should be kept lower than the operating temperature rating of the capacitor. TECATE recommends reconditioning any capacitors that have been stored for a period of greater than 6 months. Reconditioning is accomplished by applying a low voltage through a 1K ohm series resistor and slowly ramping the voltage up to the rated voltage. Lower voltage capacitors have a longer shelf life than high voltage capacitors before needing to be reconditioned.

EFFECT OF SURGES

- The solid tantalum capacitor has a limited ability to with-stand surges (15% to 30% of rated voltage). This is in common with all electrolytic capacitors and is due to the fact that they operate at very high electrical stress within the oxide layer. In the case of 'solid' electrolytic capacitors this is further complicated by the limited self healing ability of the manganese dioxide semiconductor.
- It is important to ensure that the voltage across the terminals of the capacitor does not exceed the surge voltage rating at any time. This is particularly so in low impedance circuits where the capacitor is likely to be subjected to the full impact of surges, especially in low inductance applications. Even an extremely short duration spike is likely to cause damage.
- In such situations it will be necessary to use a higher voltage rating.

REVERSE VOLTAGE AND NON-POLAR OPERATION

- The reverse voltage ratings are designed to cover exceptional conditions of small level excursions into in-correct polarity. The values quoted are not intended to cover continuous reverse voltage operations.
- The peak reverse voltage applied to the capacitor must not exceed:
 - 10% of rated DC working voltage to a maximum of 1V at 25°C.
 - 3% of rated DC working voltage to a maximum of 0.5V at 85°C.
 - 1% of category DC working voltage to a maximum of 0.1V at 125°C.

NON-POLAR OPERATION

- If the higher reverse voltages are essential, then two capacitors, each of twice the required capacitance and of equal tolerance and rated voltage, should be connected in a back-to-back configuration, i.e., both anodes or both cathodes joined together. This is necessary in order to avoid a reduction in life expectancy.

SUPERIMPOSED AC VOLTAGE (V_{RMS}) RIPPLE VOLTAGE

- This is the maximum RMS voltage, superimposed on a DC voltage, that may be applied to a capacitor. The sum of the DC voltage and the surge value of the super-imposed AC voltage must not exceed rated voltage.

FORMING VOLTAGE

- The voltage at which the anode oxide is formed. The thickness of this oxide is proportional to the voltage in a tantalum capacitor.

LEAKAGE CURRENT

- Measurement is made at rated voltage and 20°C with 1000Ω in series with the capacitor after 5 minutes.

LEAD FREE REFLOW SOLDER PROFILE FOR 522 SERIES

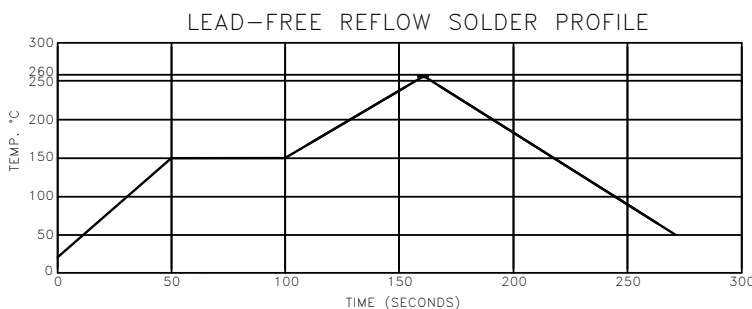

10 SECONDS MAX @ 260°C

TAPE & REEL QUANTITIES

CASE SIZE	TAPE WIDTH	P (mm)	7"(178mm) REEL QTY.	13"(330mm) REEL QTY.
A	8	4	2000	9000
8	8	4	2000	8000
C	12	8	500	3000
D	12	8	500	2500
E	12	8	400	1500
Y	12	8	400	1500

RECOMMENDED LAND PATTERN

SIZE	A (REFLOW)	A (WAVE)	B	C	D
A	11.8(0.071)	0.9(0.054)	1.4(0.054)	1.2(0.047)	4.0(0.157)
B	2.8(0.110)	1.6(0.063)	1.1(0.054)	1.2(0.047)	4.0(0.137)
C	2.8(0.110)	1.6(0.063)	2.0(0.078)	2.5(0.098)	6.5(0.256)
D	3.0(0.119)	1.7(0.068)	2.0(0.079)	4.0(0.157)	8.0(0.315)
E	3.0(0.119)	1.7(0.068)	2.0(0.078)	4.0(0.157)	8.0(0.315)
V	6.2(0.245)	1.7(0.068)	2.3(0.090)	3.7(0.145)	18.3(0.325)

Tape and Reel packaging for automatic component placement.
Bulk product is not available.

Case Size reference	Tape width mm	P mm	7"(1/8mm) reel Qty.	13"(330mm) reel Qty.
A	8	4	2000	9000
B	8	4	2000	8000
C	12	8	500	3000
D	12	8	500	2500
E	12	8	400	1500

Total Tape Thickness – K max	
Case Size	Dimension
A	0.090 (2.3)
B	0.102 (2.6)
C	0.130 (3.3)
D	0.142 (3.6)
E	0.189 (4.8)

TAPE SPECIFICATION

Tape dimensions comply to EIA RS 481 A

Dimensions A_0 and B_0 of the pocket and the tape thickness, K , are dependent on the component size.

Tape materials do not affect component solderability during storage.

Carrier Tape Thickness $< 0.4\text{mm}$

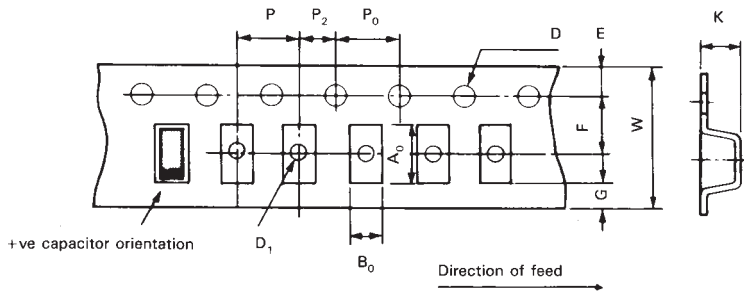

Plastic Tape Reel Dimensions

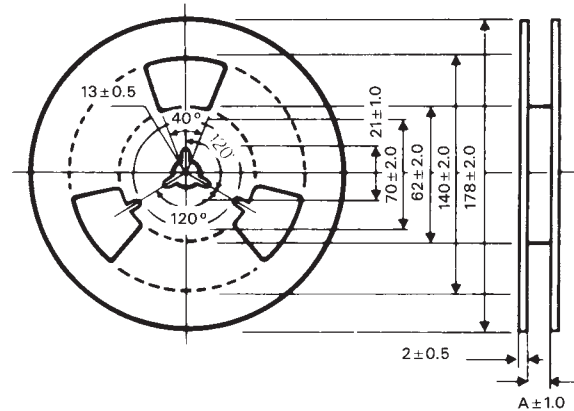

CODE	8mm Tape		12mm Tape	
P*	0.157 ± 0.004 or 0.315 ± 0.004	(4 ± 0.1) (8 ± 0.1)	0.157 ± 0.004 or 0.315 ± 0.004	(4 ± 0.1) (8 ± 0.1)
G	0.03 min	1.75 min	0.03 min	1.75 min
F	0.138 ± 0.002	3.5 ± 0.05	0.22 ± 0.002	5.5 ± 0.05
E	0.069 ± 0.004	1.75 ± 0.1	0.069 ± 0.004	1.75 ± 0.1
W	0.315 ± 0.012	8 ± 0.3	0.315 ± 0.012	12 ± 0.3
P2	0.079 ± 0.002	2 ± 0.05	0.079 ± 0.002	2 ± 0.05
P0	0.157 ± 0.004	4 ± 0.1	0.157 ± 0.004	4 ± 0.1
D	0.059 ± 0.004 -0	1.5 ± 0.1 -0	0.059 ± 0.004 -0	1.5 ± 0.1 -0
D1	0.039 min	1.0 min	0.059 min	1.5 min

*See taping suffix tables for actual P dimension (component pitch).

Standard dimensions mm

A: 9.5mm (8mm tape)
13.0mm (12mm tape)

Cover Tape Dimensions

Thickness: 75 ± 25μ

Width of tape:

5.5mm + 0.2mm (8mm tape)

9.5mm + 0.2mm (12mm tape)