

IGBT Module, 1200V/100A

Features

- FS Trench technology
- Low switching losses
- $V_{CE(sat)}$ with positive temperature coefficient
- Low saturation voltage, $V_{CE(sat)}$

Applications

- AC inverter drives
- Servo drives
- UPS systems
- Power supplies

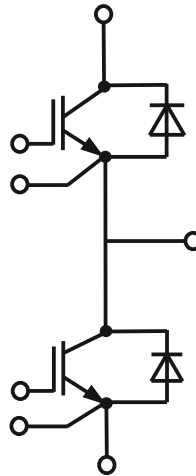

Absolute Maximum Ratings ($T_C = 25^{\circ}\text{C}$ unless otherwise noted)

IGBT				
Parameter	Conditions	Symbol	Values	Units
Collector-to-Emitter Voltage		V_{CE}	1200	V
Gate-to-Emitter Voltage		V_{GE}	± 30	V
DC Collector Current	$T_j = 25^{\circ}\text{C}$	I_C	200	A
	$T_j = 100^{\circ}\text{C}$		100	
Pulsed Collector Current		I_{CM}	800	A
Short circuit withstand time	$V_{GE} = 15\text{V}, V_{CC} = 600\text{V}, V_{CES} < 1200\text{V}, T_j = 150^{\circ}\text{C}$	T_{sc}	10	μs

Diode				
Parameter	Conditions	Symbol	Values	Units
Peak Repetitive Reverse Voltage		V_{RRM}	1200	V
DC Blocking Voltage		V_R	1200	V
Average Rectified Forward Current		$I_{F(AV)}$	100	A
Repetitive Peak Surge Current		I_{FRM}	200	A
Non-repetitive Peak Surge Current	$t_p = 10\text{ ms}$	I_{FSM}	600	A

Module				
Parameter	Conditions	Symbol	Values	Units
Junction Temperature Range		T_{jmax}	-45...+175	$^{\circ}\text{C}$
Operating Junction Temperature		T_{jop}	-45...+150	$^{\circ}\text{C}$
Storage Temperature Range		T_{stg}	-45...+150	$^{\circ}\text{C}$
Isolation Voltage	$f = 50\text{Hz}, t = 1\text{ min.}$	V_{iso}	4000	V

Electrical Characteristics ($T_C = 25^\circ\text{C}$ unless otherwise noted)

IGBT							
Parameter	Conditions	Symbol	Min.	Typ.	Max.	Units	
Collector-to-Emitter Breakdown Voltage	$I_C = 250 \mu\text{A}, V_{GE} = 0\text{V}, T_j = 25^\circ\text{C}$	$V_{(BR)CES}$	1200	-	-	V	
Collector-to-Emitter Leakage Current	$V_{CE} = 1200\text{V}, V_{GE} = 0\text{V}, T_j = 25^\circ\text{C}$	I_{CES}	-	-	20	μA	
	$V_{CE} = 1200\text{V}, V_{GE} = 0\text{V}, T_j = 150^\circ\text{C}$		-	-	1.0	mA	
Gate-to-Emitter Leakage Current	$V_{GE} = \pm 30\text{V}, V_{CE} = 0\text{V}, T_j = 25^\circ\text{C}$	I_{GES}	-	-	± 200	nA	
	$V_{GE} = \pm 30\text{V}, V_{CE} = 0\text{V}, T_j = 150^\circ\text{C}$		-	-	± 400		
Gate Threshold Voltage	$V_{CE} = V_{GE}, I_C = 2 \text{ mA}$	$V_{GE(th)}$	4	4.8	6	V	
Collector-emitter saturation voltage	$V_{GE} = 15\text{V}, I_C = 100\text{A}, T_j = 25^\circ\text{C}$	V_{CEsat}	-	1.9	2.4	V	
	$V_{GE} = 15\text{V}, I_C = 75\text{A}, T_j = 150^\circ\text{C}$		-	2.5	-		
Input Capacitance	$V_{CE} = 25\text{V}, V_{GE} = 0\text{V}, f = 1\text{MHz}, T_a = 25^\circ\text{C}$	C_{iss}	-	12966	-	pF	
Output Capacitance		C_{oss}	-	374	-		
Reverse Transfer Capacitance		C_{rss}	-	80	-		
Turn-on delay time	$V_{CE} = 600\text{V}, I_C = 100\text{A}, R_g = 10\Omega, V_{GE} = 15\text{V}, T_j = 25^\circ\text{C}$	$t_{d(on)}$	-	80	-	ns	
Rise time		t_r	-	72	-	ns	
Turn-off delay time		$t_{d(off)}$	-	744	-	ns	
Fall time		t_f	-	228	-	ns	
Turn-on energy		E_{on}	-	1.88	-	mJ	
Turn-off energy		E_{off}	-	5.06	-	mJ	
Total switching energy		E_{ts}	-	6.94	-	mJ	
Turn-on delay time		$V_{CE} = 600\text{V}, I_C = 100\text{A}, R_g = 10\Omega, V_{GE} = 15\text{V}, T_j = 150^\circ\text{C}$	$t_{d(on)}$	-	68	-	ns
Rise time			t_r	-	72	-	ns
Turn-off delay time			$t_{d(off)}$	-	896	-	ns
Fall time	t_f		-	476	-	ns	
Turn-on energy	E_{on}		-	2.2	-	mJ	
Turn-off energy	E_{off}		-	6.76	-	mJ	
Total switching energy	E_{ts}		-	8.96	-	mJ	
Gate charge	$V_{CE} = 960\text{V}, I_C = 100\text{A}, V_{GE} = 15\text{V}$	Q_g	-	658	-	nC	

Diode						
Parameter	Conditions	Symbol	Min.	Typ.	Max.	Units
Diode forward voltage	$I_F = 100\text{A}, T_j = 25^\circ\text{C}$	V_F	-	3.1	3.5	V
	$I_F = 100\text{A}, T_j = 150^\circ\text{C}$		-	1.9	-	
Diode reverse recovery time	$I_F = 0.5\text{A}, I_R = 1.0\text{A}, I_{rr} = 0.25\text{A}$	t_{rr}	-	50	-	ns
Diode reverse recovery time	$I_F = 100\text{A}, di/dt = 200 \text{ A}/\mu\text{s}, V_R = 400\text{V}$	t_{rr}	-	155	-	ns
Diode peak reverse recovery current		I_{RRM}	-	15	-	A
Diode reverse recovery charge		Q_{rr}	-	560	-	nC
Maximum Instantaneous Reverse	$V_R = 1200\text{V}, T_j = 25^\circ\text{C}$	I_R	-	-	5.0	μA
	$V_R = 1200\text{V}, T_j = 150^\circ\text{C}$		-	-	1.0	mA



Module						
Parameter	Conditions	Symbol	Min.	Typ.	Max.	Units
Stray inductance		L_{CE}			30	nH
Thermal resistance	per IGBT	$R_{th(j-c)}$			0.28	$^{\circ}C/W$
	per Diode				0.40	
Mounting torque	to terminal M5	F	2.5		5.0	Nm
	to heatsink M6		3.0		5.0	
Weight		W			150	g

Characteristic Curves

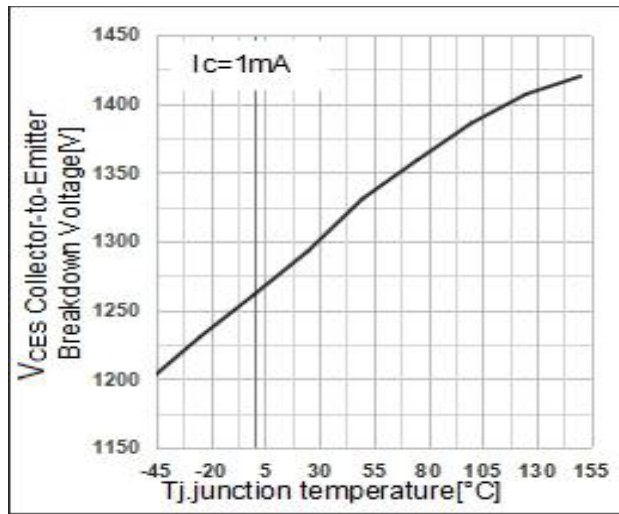

Collector-to-Emitter Breakdown Voltage

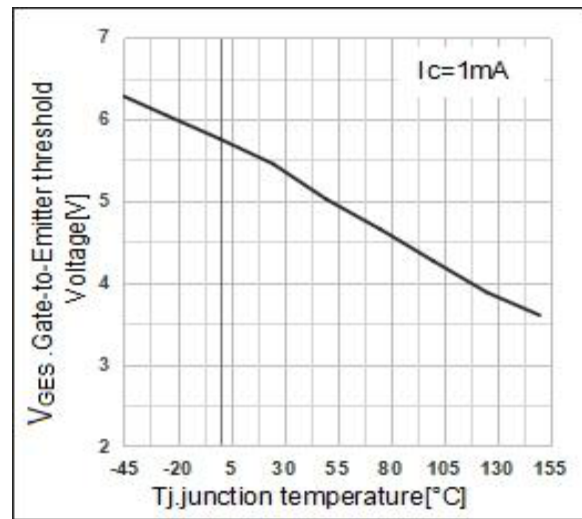

Gate-to-Emitter Threshold Voltage

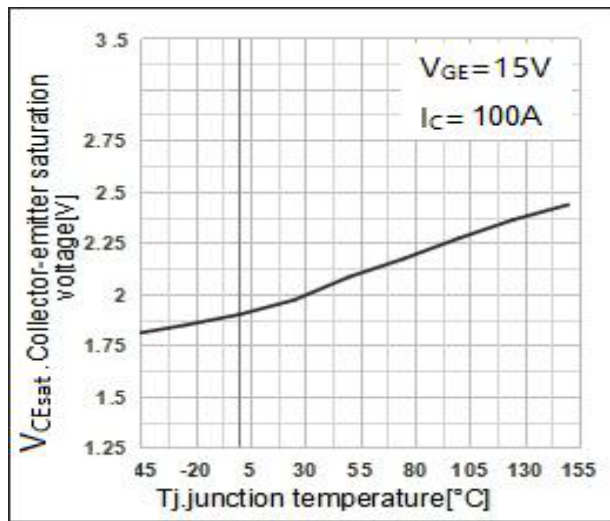

Collector-emitter saturation voltage of temperature characteristic

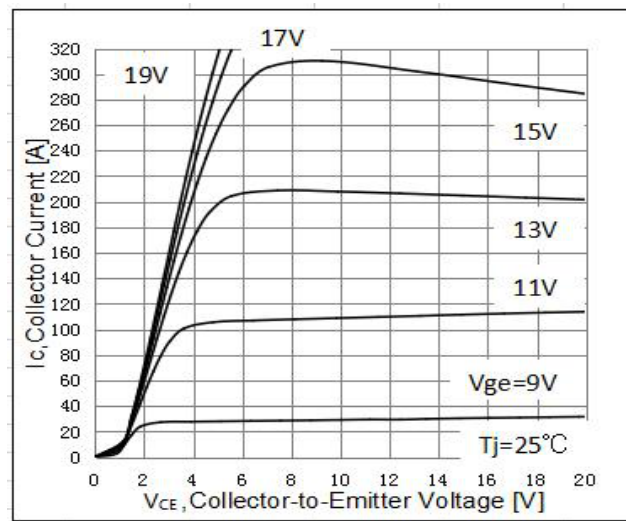

Typical output characteristic

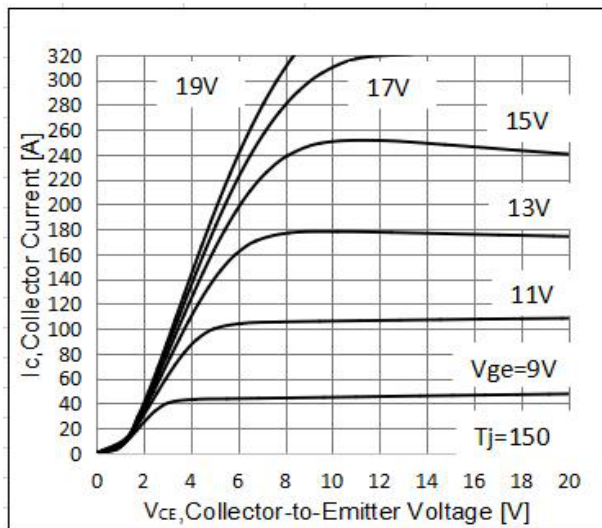

Typical output characteristic

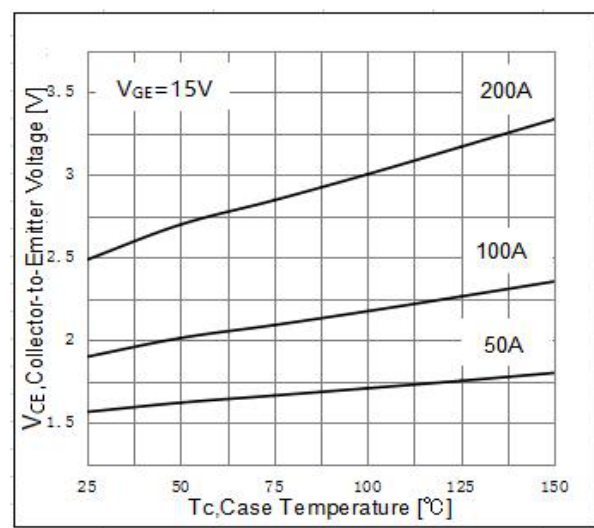

Collector-emitter saturation voltage Temperature Characteristic

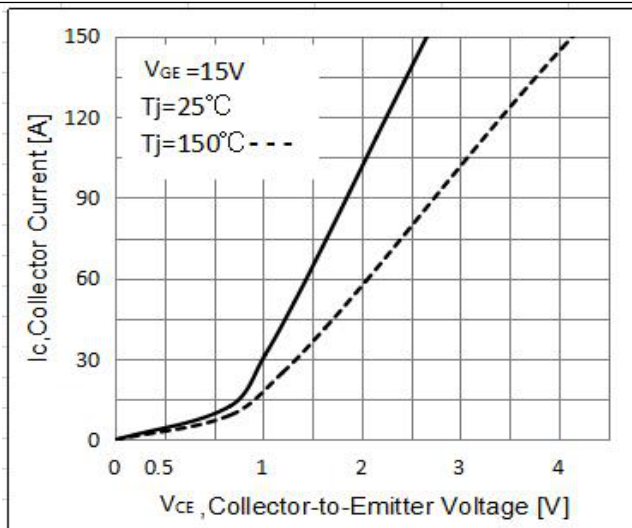

**Collector-emitter saturation voltage
Characteristic**

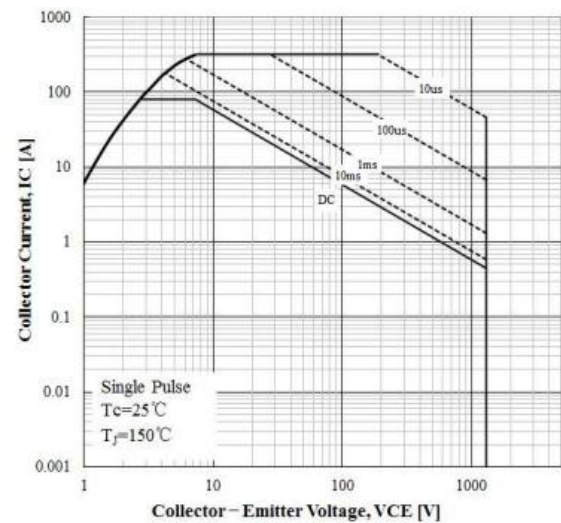

Forward bias safe operating area

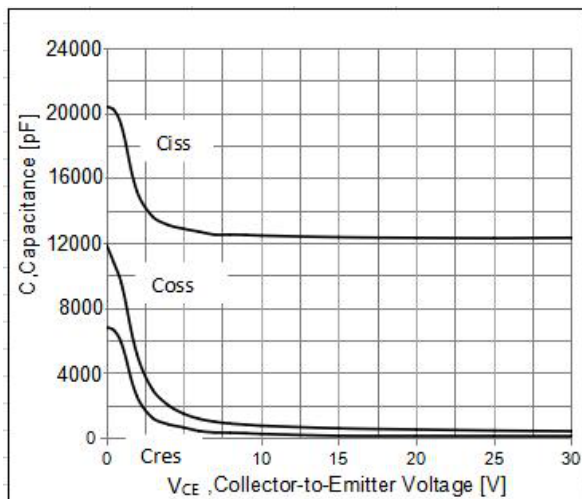

**Typical capacitance as a function of
collector-emitter voltage**

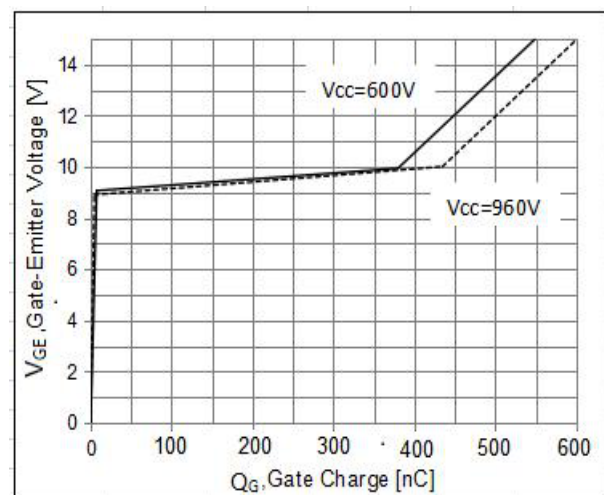

Typical gate charge

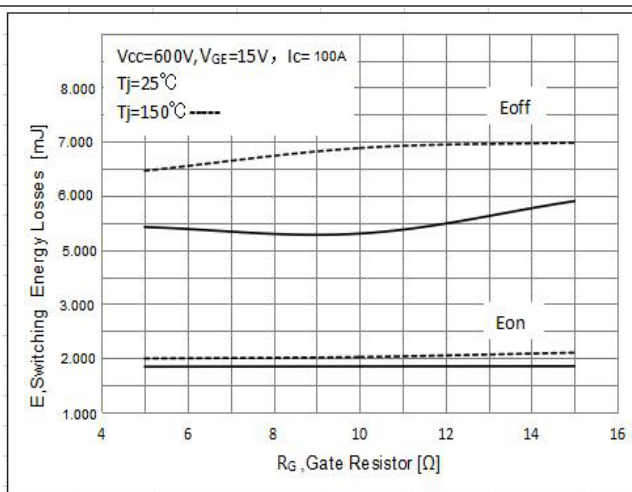

**Typical switching energy losses as a
function of gate resistor**

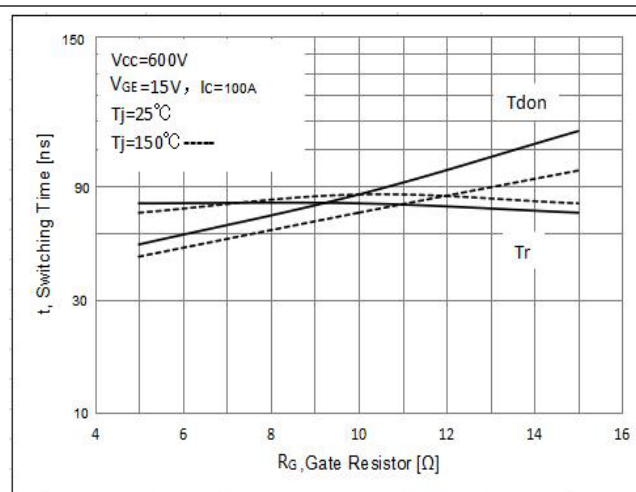

**Typical switching times as a function
of gate resistor**

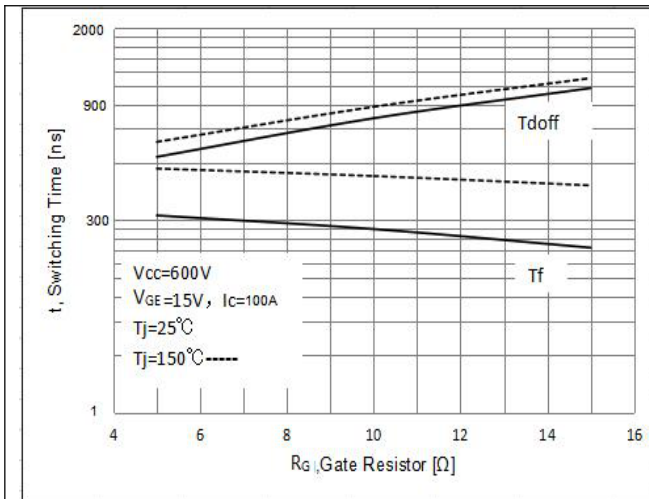

Typical switching times as a function of gate resistor

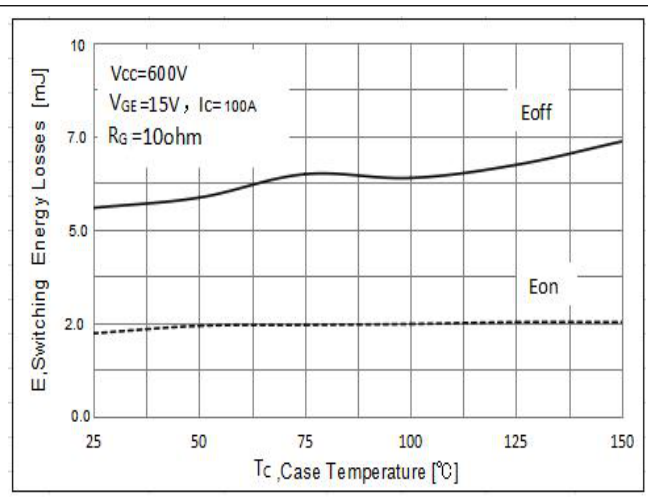

Typical switching energy losses as a function of Case Temperature

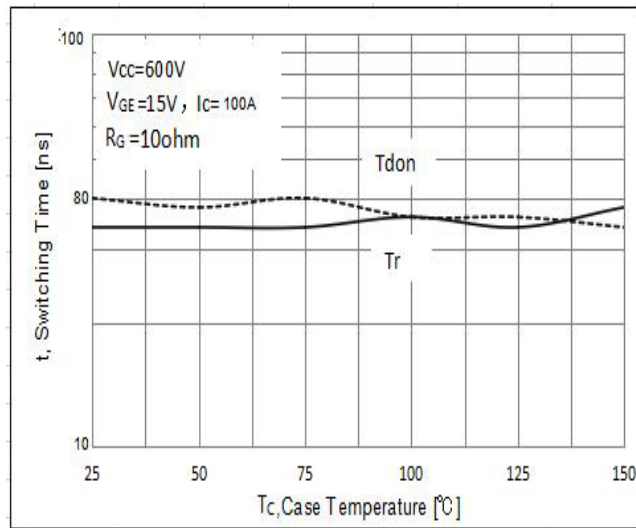

Typical switching times as a function of Case Temperature

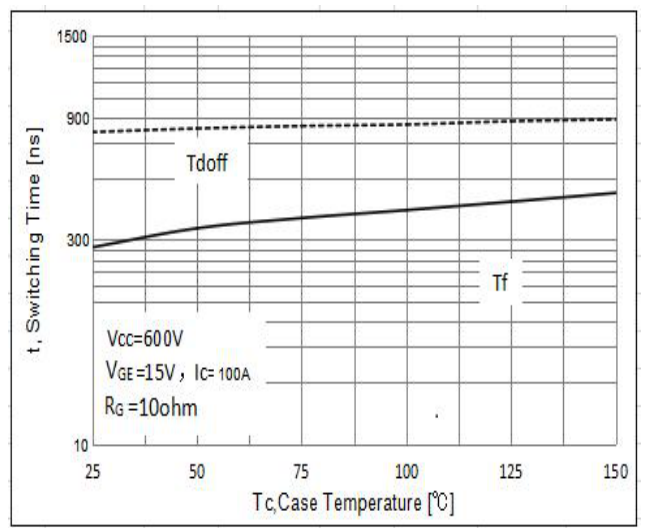

Typical switching times as a function of Case Temperature

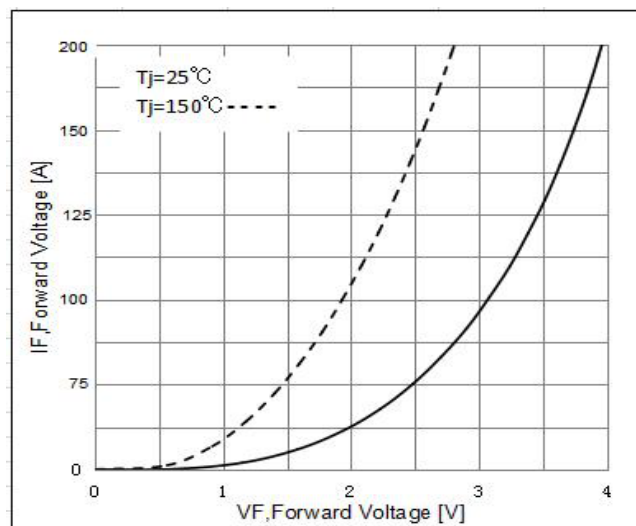

Typical diode forward current as a function of forward voltage

Circuit Schematic

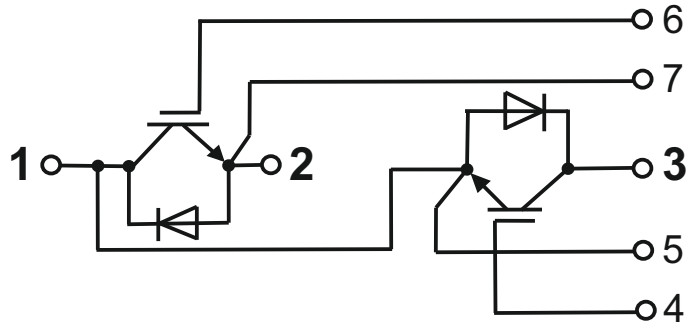

Package Outline

(All dimensions in mm)

