

Schottky Power Diode, 40A

Features

- Fast Switching
- Low forward voltage drop
- High surge capability
- High efficiency, low power loss
- Normal and Reverse polarity



DO-203AB (DO-5)

Maximum Ratings ($T_J = 25^\circ\text{C}$, unless otherwise noted)						
Parameter	Test Conditions	Symbol	1N5832(R)	1N5833(R)	1N5834(R)	Units
Repetitive peak reverse voltage		V_{RRM}	20	30	40	V
RMS reverse voltage		V_{RMS}	14	21	28	V
DC blocking voltage		V_{DC}	20	30	40	V
Continuous forward current	$T_C \leq 100^\circ\text{C}$	I_F	40	40	40	A
Surge non-repetitive forward current, half-sine wave	$T_C = 25^\circ\text{C}$	I_{FSM}	800	800	800	A
Forward voltage	$I_F = 40\text{ A}$ $T_J = 25^\circ\text{C}$	V_F	0.52	0.55	0.58	V
Reverse current	$V_R = 10\text{V}, T_J = 25^\circ\text{C}$	I_R	20	20	20	mA
	$V_R = 10\text{V}, T_J = 125^\circ\text{C}$		250	250	250	

Thermal & Mechanical Specifications ($T_J = 25^\circ\text{C}$, unless otherwise noted)					
Parameters	Symbol	1N5832(R)	1N5833(R)	1N5834(R)	Units
Maximum thermal resistance, junction to case	$R_{th(jc)}$	1.5			$^\circ\text{C}/\text{W}$
Operating junction temperature range	T_J	-65 to 150			$^\circ\text{C}$
Storage temperature	T_{stg}	-65 to 175			$^\circ\text{C}$
Mounting torque (non-lubricated threads)	F	4.0			Nm
Approximate allowable weight	W	17.0			g

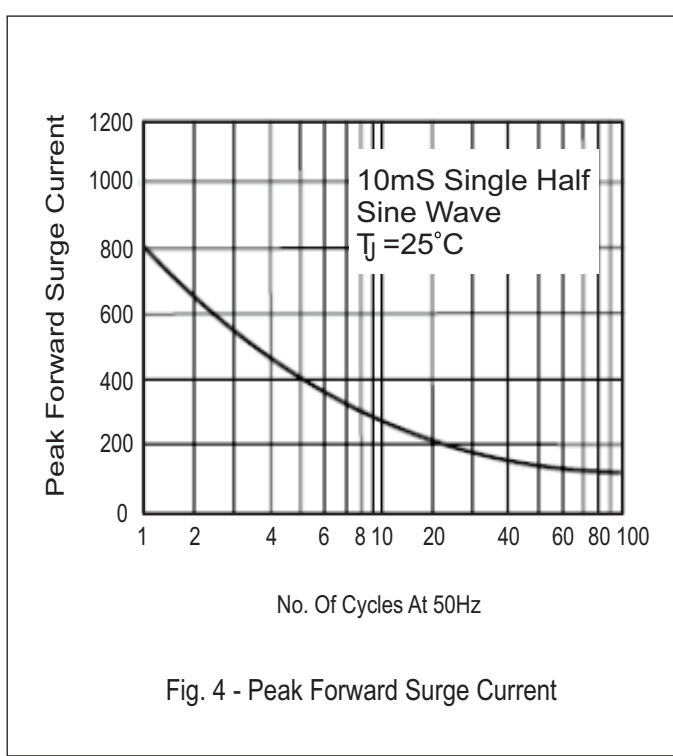
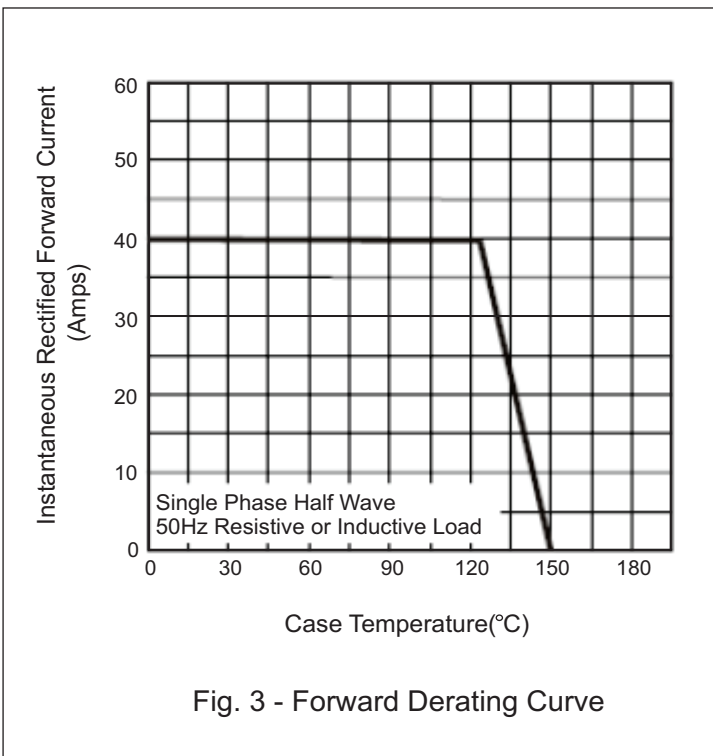
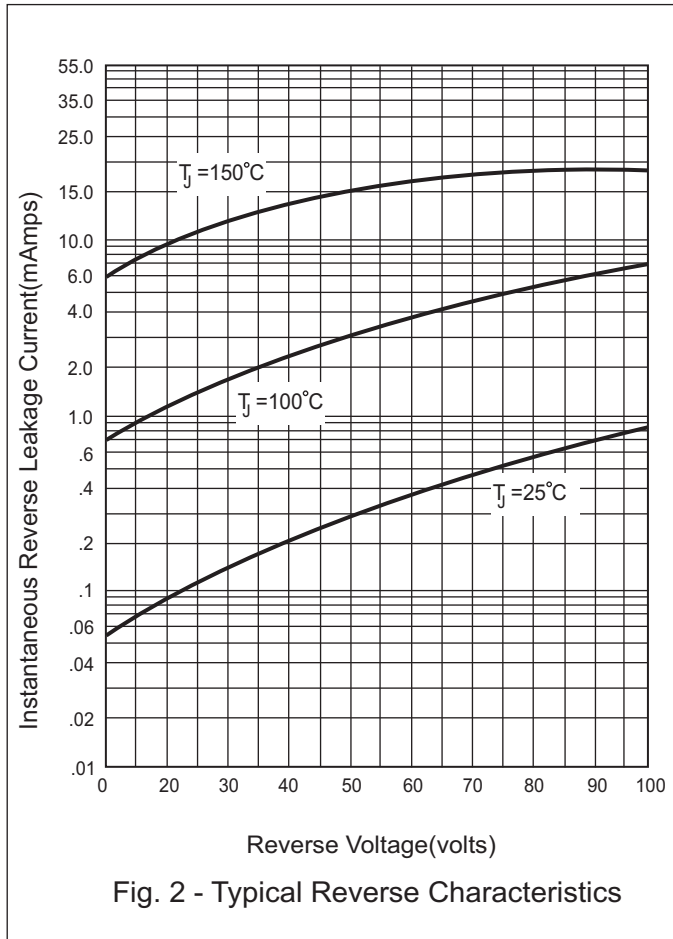
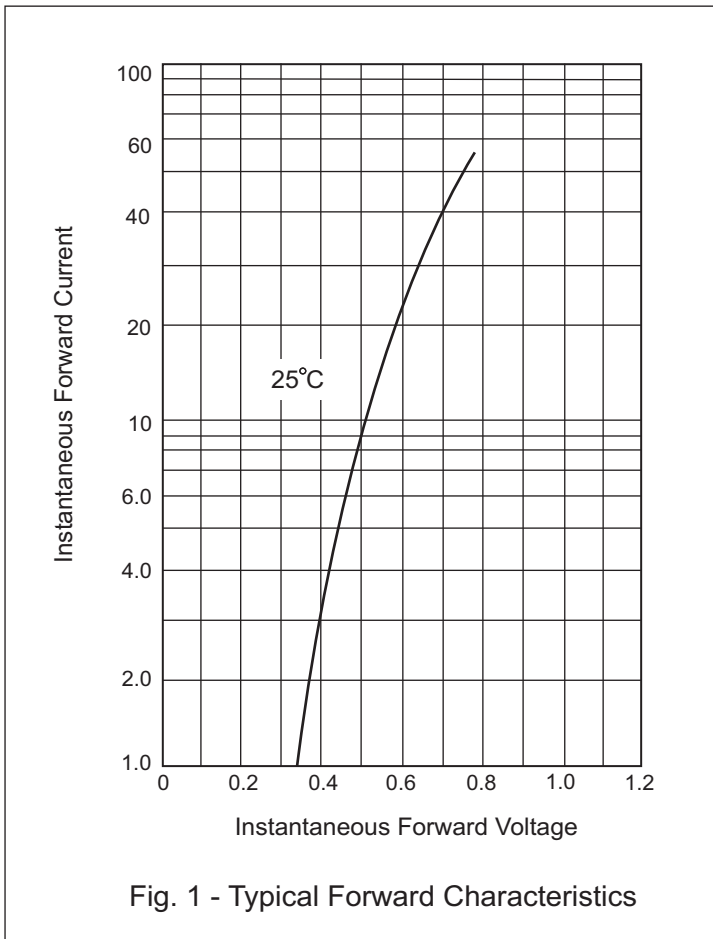

Package Outline

DO-203AB (DO-5)

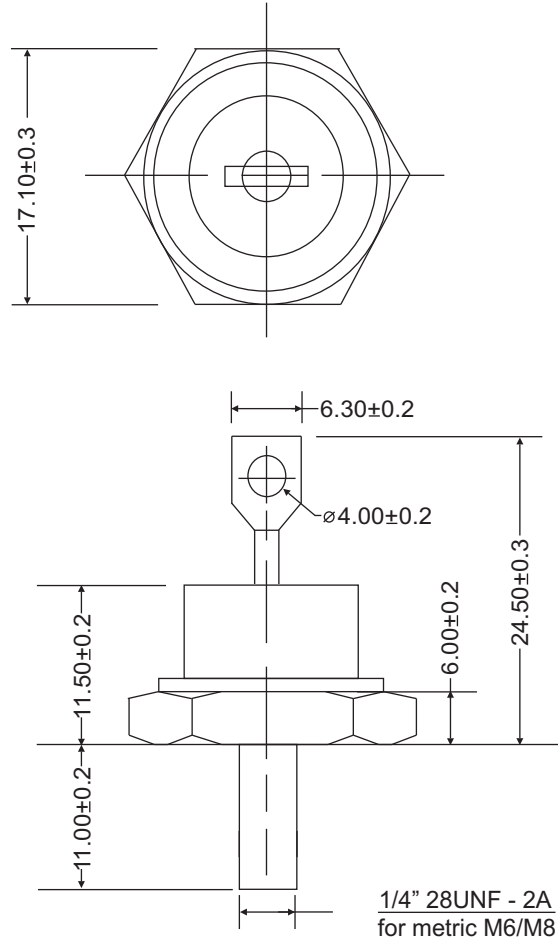

ALL DIMENSIONS IN MM